



Cat[®] CD54B

DRUM STEER VIBRATORY ROLLER

Top Features

The Cat[®] CD54B is a 10 ton drum-steer roller with 1700 mm (67") vibratory drums. It offers excellent visibility, simple vibratory selection, wide mat coverage, and is available in solid or split drum models. This machine excels on a variety of asphalt mix designs as well as other granular materials.

- **Exceptional visibility and control** with handwheel steering technology, touch-pad machine functions, ECO-mode operation, and automatic speed control. This machine can be equipped with a Cab or ROPS/FOPS.
- **Smooth operating powertrain** with C3.4B engine that meets U.S. EPA Tier 4 Interim and E.U. Stage IIIB emissions standards. The split drum design delivers superior mat quality and smooth performance when turning. Four steering modes provide excellent maneuverability, while the large drum offset expands mat coverage. The traction control system automatically actuates and delivers a balanced torque to each drum.
- **Versatile vibratory performance** delivered with dual amplitude, dual frequency vibratory system that automatically matches frequency and amplitude at the flip of a switch. Easily adjustable for thin and thick lift applications.
- **Cat[®] Compaction Control** keeps the operator informed for higher performance and efficiency. Infrared temperature sensors combined with mapping keep the operator informed of when optimal temperatures exist and where compaction has taken place. Temperature Mapping records temperatures for data analysis, while Pass-Count Mapping keeps the operator informed of where mat coverage has taken place and the number of passes made.
- **Industry-Leading Water Spray System** features dual water pumps, triple filtration, intermittent operation and high capacity for optimal performance. An optional freeze protection kit offers protection in cold temperatures.
- **Unmatched Uptime** with ECO-mode operation conserves fuel, while oil-bath lubrication and 3 yr/3000 hr vibratory drum service interval extends operation and minimizes life-time operating costs.

Specifications

Weights

Operating Weight – Split Drum w/ROPS/FOPS/CAB

Standard machine	10 120 kg	22,311 lb
Maximum machine	11 440 kg	25,220 lb
Static linear load	29.5 kg/cm	165 lb/in

Operating Weight – Solid Drum w/ROPS/FOPS/CAB

Standard machine	9030 kg	19,908 lb
Maximum machine	9740 kg	21,475 lb
Static linear load	26.5 kg/cm	148 lb/in

Operating Weight – Split Drum w/ROPS/FOPS/CANOPY

Standard machine	9860 kg	21,738 lb
Maximum machine	11 170 kg	24,625 lb
Static linear load	28.6 kg/cm	160 lb/in

Operating Weight – Solid Drum w/ROPS/FOPS/CANOPY

Standard machine	8770 kg	19,335 lb
Maximum machine	9470 kg	20,880 lb
Static linear load	25.8 kg	145 lb/in

Engine – Powertrain

Engine Model	Cat [®] C3.4B	
Number of Cylinders	4	
Rated Speed	2200 rpm	
Bore	99 mm	3.89"
Stroke	110 mm	4.33"
Gross Power:		
Tier 4 Interim, Stage IIIB	75 kW	100.5 hp (l), 101.9 hp (m)
Speed Ranges:		
Low	0 - 7 km/hr	4.3 mph
High	0 - 12 km/hr	7.5 mph
Gradeability (no vibs):		
Solid drum	32°	
Split drum	39°	
Steering (Inside)	2.8 m	(9' 3")
Articulation Angle	25°	



CD54B Drum Steer Vibratory Roller

Dimensions

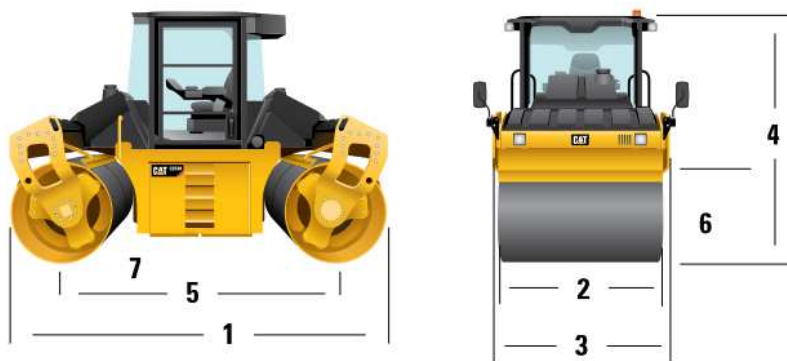

1 Overall length	4322 mm	14' 2"
2 Drum width	1700 mm	67"
Drum offset	1320 mm	51"
Max. compaction width	3020 mm	118"
Drum shell thickness	17 mm	0.67"
Drum diameter	1202 mm	44"
3 Overall width	1874 mm	6' 2"
4 Height at ROPS/FOPS	2990 mm	9' 8"
Height at cab	2985 mm	9' 9"
5 Wheelbase	3120 mm	10' 3"
6 Curb clearance	808 mm	31"
7 Ground clearance	272 mm	10"

Vibratory Systems

Dual Amplitude, Dual Frequency - Split Drum

Frequency – Hz (vpm)	42/53.3	(2520/3200)
Amplitude – mm (in)	0.61 - 0.33	(0.023 - 0.013)

Dual Amplitude, Dual Frequency - Solid Drum

Frequency – Hz (vpm)	45/53.3	(2700/3200)
Amplitude – mm (in)	0.82 - 0.32	(0.026 - 0.013)

Service Refill Capacities

Fuel Tank	191 L	50 gal
Fuel Usage (50% duty)	12 hours	
Cooling System	15	3.9 gal
Engine Oil	9	2.4 gal
Hydraulic Tank	36 L	9.5 gal
Water Tank	750 L	198 gal

Standard and Optional Equipment

STANDARD EQUIPMENT:

- Front and Rear Split Drums
- Dual Amplitude, Dual Frequency Vibratory System
- Sealed Pod Vibratory System
- ROPS/FOPS Cab
- Two-Speed Hydrostatic Transmission
- Automatic Traction Control
- Locking Engine Compartment
- Triple Filtered Water Spray System
- 750 L Water Tank Capacity
- 12-Volt Electrical System
- 120 Amp Alternator
- Suspension Seat
- Roofing Lights

OPTIONAL EQUIPMENT:

- Air Conditioning
- Bio-Degradeable Oil
- Freeze Protection Kit
- Mirrors
- Warning Beacon
- Water Distribution Mats (cocoa)
- Water Distribution Mats (rubber)
- Product Link
- Recording Module (cab only)
- Edge Cutter
- Chip Spreader Ready (split drum)
- Air Suspension Seat w/Heat
- High Ambient Cooling System
- Temperature Gauge
- AccuGrade Temperature and Pass-Count Mapping
- Halogen Lights w/Drum Edge Lights
- High Intensity Discharge (HID) w/ Drum Edge Lighting
- Temperature Gauge (single sensor)
- Front and Rear Solid Drums
- ROPS/FOPS Open Platform
- IRH Compliant

For more complete information on Cat products, dealer services, and industry solutions, visit us on the web at www.cat.com

QEHQ1587-01 (9-12)

© 2012 Caterpillar
All Rights Reserved

Materials and specifications are subject to change without notice. Featured machines in photos may include additional equipment. See your Cat dealer for available options.

CAT, CATERPILLAR, SAFETY.CAT.COM, their respective logos, "Caterpillar Yellow" and the "Power Edge" trade dress, as well as corporate and product identity used herein, are trademarks of Caterpillar and may not be used without permission.

