



Cat[®] Cold Planers

Skid Steer Loaders
Multi Terrain Loaders
Compact Track Loaders
Compact Wheel Loaders

Cat[®] Cold Planers are designed for small paving jobs in residential and commercial applications, and are primarily used to economically restore asphalt and concrete surfaces. They are ideal for milling imperfections prior to resurfacing, removing deteriorated pavement, removing traffic lane stripes and jobs where the use of dedicated planers is limited.

Features:

Self-leveling design

- Self-leveling design automatically levels itself when placed on the ground for consistent depth control without operator adjustments and excellent spoil retention.

Two wear resistant skid plates

- Two wear resistant skid plates remain parallel to the ground for optimum stability.

Hydraulic side-shift

- Hydraulic side-shift permits close planing to curbs, walls and other obstructions.

Independent left/right depth control

- Independent left/right depth control allows maximum drum depths to be adjusted independently on each skid. The gauges are easily viewable from the cab. Independent depth control is mechanical on standard flow planers and hydraulic on high flow planers.

Spring tilt and hydraulic tilt

- Spring tilt and hydraulic tilt enable planers to oscillate for angled cuts. Tilt is hydraulically controlled on high flow models and spring controlled on standard flow planers.

Direct drive on standard flow and planetary drive on high flow

- Direct drive system on the standard flow models features a variable speed, uni-directional, gerotor style hydraulic motor. Planetary drive system on the high flow models features a variable speed, uni-directional, axial piston style hydraulic motor mounted to a double reduction gearbox.

Optional concrete bits and water sprinkler kits

- Optional concrete bits and water sprinkler kits are available for all models.

Cat XT[™] and medium pressure hose, couplings and O-ring face seals

- Cat XT and medium pressure hose, couplings and O-ring face seals provide superior, leak-free performance and reliability. All hoses are wrapped with nylon woven cordura sleeving for added operator protection. Hydraulic quick disconnects enable fast tool changes.

Quick coupler

- Rugged, opposing edge design holds the work tool securely and allows the operator to quickly change from one high performance Cat Work Tool to another.

Compatibility

Model Machines

PC203 216B, 226B, 232B, 236B, 242B, 247B, 252B, 257B, 246C, 256C, 262C, 272C, 277C, 287C, 297C, 279C, 289C, 299C, 904B, 906H, 908H

PC204 226B, 236B, 242B, 252B, 257B, 246C, 256C, 262C, 272C, 277C, 287C, 297C, 279C, 289C, 299C, 904B, 906H, 908H

PC205* 226B, 242B, 257B, 246C, 256C, 262C, 272C, 277C, 287C, 297C, 279C, 289C, 299C, 906H, 908H

PC206* 246C, 256C, 262C, 272C, 277C, 287C, 297C, 279C, 289C, 299C, 906H, 908H

PC210* 246C, 256C, 262C, 272C, 277C, 287C, 297C, 279C, 289C, 299C, 906H, 908H

* Requires high flow or high flow XPS option on machine.

Cat Cold Planers

Specifications

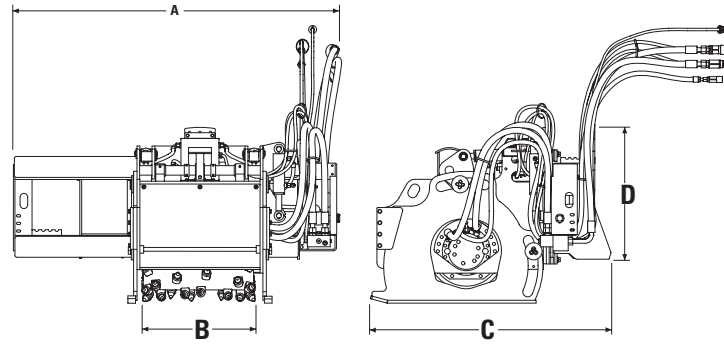

			PC203	PC204	PC205	PC206	PC210
A Overall width	mm (in)		1720 (68)	1720 (68)	1720 (68)	1720 (68)	1720 (68)
B Maximum drum width	mm (in)		350 (14)	450 (18)	450 (18)	600 (24)	1000 (38)
C Length	mm (in)		1180 (46)	1180 (46)	1184 (46)	1265 (50)	1130 (44)
D Overall height	mm (in)		840 (33)	840 (33)	990 (39)	950 (37)	890 (35)
Weight	kg (lb)		650 (1,433)	690 (1,521)	750 (1,654)	906 (1,998)	1080 (2,381)
Required hydraulic flow	L/min (gpm)		55-100 (14-26)	55-100 (14-26)	80-125 (21-33)	95-140 (25-37)	95-180 (25-48)
Optimal hydraulic pressure	bar (psi)		160-240 (2,320-3,480)	160-240 (2,320-3,480)	160-300 (2,320-4,350)	160-300 (2,320-4,350)	160-300 (2,320-4,350)
Drum torque/max pressure	N•m lb•ft		1250 (45)	1250 (45)	2670 (600)	3720 (837)	5340 (1201)
Drum speed @ max. flow	rpm		178	178	223	160	240
Conical bits			42/350 mm (14 in) drum	48/450 mm (18 in) drum	48/450 mm (18 in) drum	60/600 mm (24 in) drum	78/1000 mm (40 in) drum
Standard bit type			All purpose	All purpose	All purpose	All purpose	All purpose
Maximum depth of cut	mm (in)		127 (5)	127 (5)	125 (5)	170 (7)	105 (4)
Optional drum widths/depths	mm (in)		80/200 (3/8) 152/200 (6/8) 203/200 (8/8) 305/200 (12/8)	80/200 (3/8) 152/200 (6/8) 203/200 (8/8) 305/200 (12/8) 350/200 (14/8) 400/200 (16/8) 450/150 (18/8) 450/150 (18/6)	80/200 (3/8) 152/200 (6/8) 305/200 (12/8) 450/150 (18/6) 450/150 (18/6)	80/200 (3/8) 152/200 (6/8)	—
Tilt angle range			±8.5°	±8.5°	±8.5°	±8.5°	±8.5°
Side-shift travel	mm (in)		650 (26)	650 (26)	650 (26)	650 (26)	465 (18)

For more complete information on Cat products, dealer services, and industry solutions, visit us on the web at www.cat.com

AEHQ5848-01 (8-08)

© 2008 Caterpillar
All Rights Reserved
Printed in U.S.A.

Replaces AEHQ5848

Materials and specifications are subject to change without notice. Featured machines in photos may include additional equipment. See your Caterpillar dealer for available options.

CAT, CATERPILLAR, SAFETY.CAT.COM, their respective logos, "Caterpillar Yellow," and the POWER EDGE trade dress, as well as corporate and product identity used herein, are trademarks of Caterpillar and may not be used without permission.

CATERPILLAR[®]
Courtesy of Machine.Market